

IAC-10.E1.2.7



Holding a technical review in an educational project:  
implementation and lessons learned for the OUFTI-1 CubeSat

A. Denis, J. Wertz, J. Pisane, G. Kerschen

University of Liège, Belgium

# Liège, Belgium



1. Context
2. Why a review ?
3. Method and implementation
4. Evaluation
5. Conclusion

# 1. The OUFTI-1 project

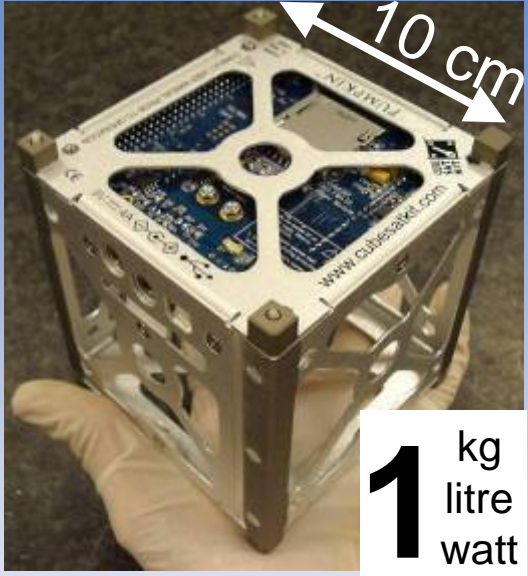

CubeSat standard



VEGA Maiden Flight



Three payloads



2 universities + 2 engineering schools

# 2. Problem: fuzzy interfaces

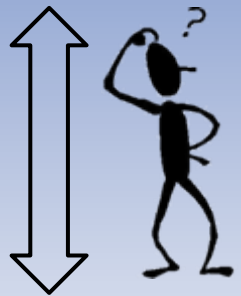
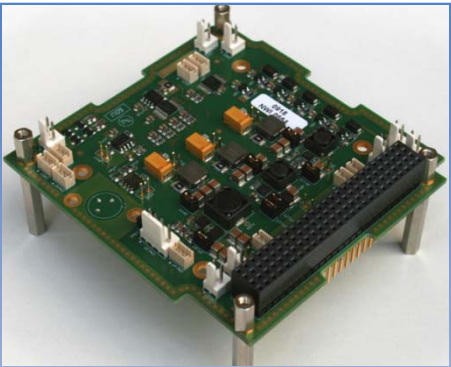
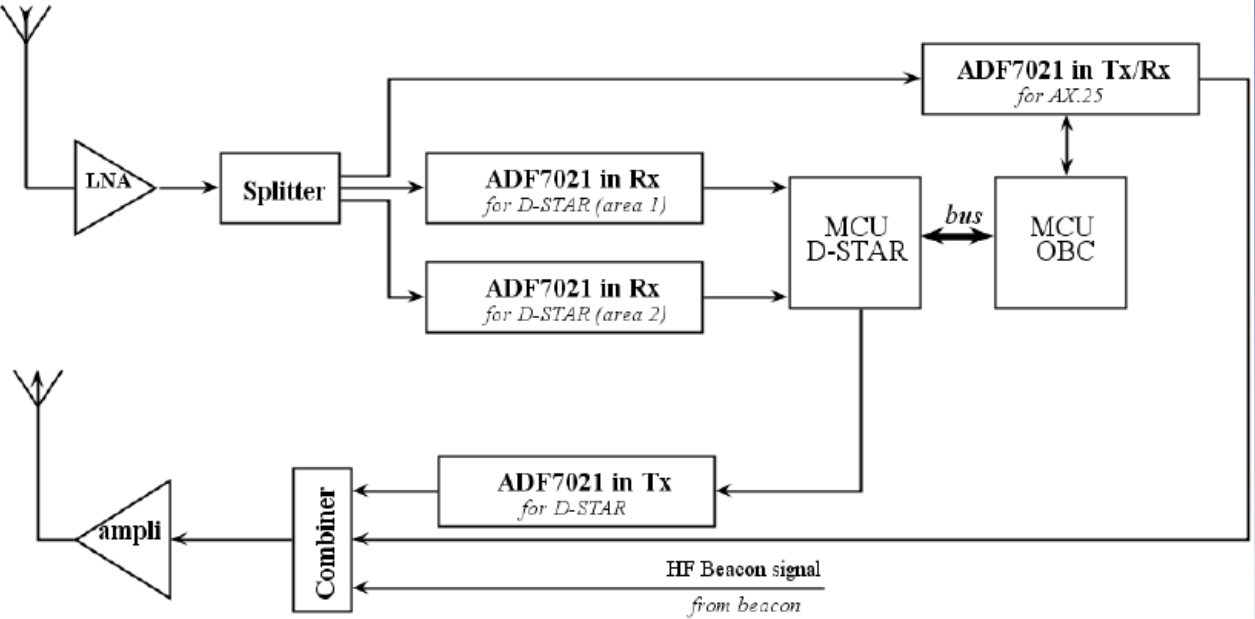

⇒ Interface Technical Review (ITR)



ECSS-M-ST-10-01:

Space Management – Organization and conduct of reviews

**Review = snapshot of the technical status**

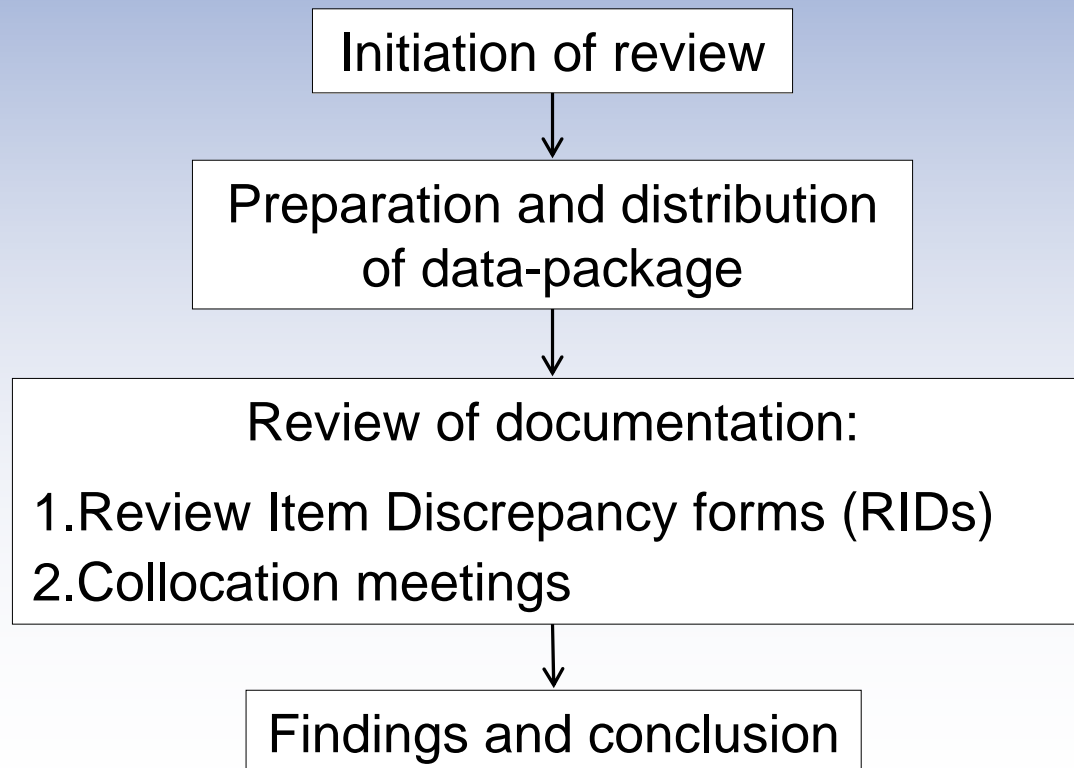

# 3. Adaptation of ECSS to our project (1)

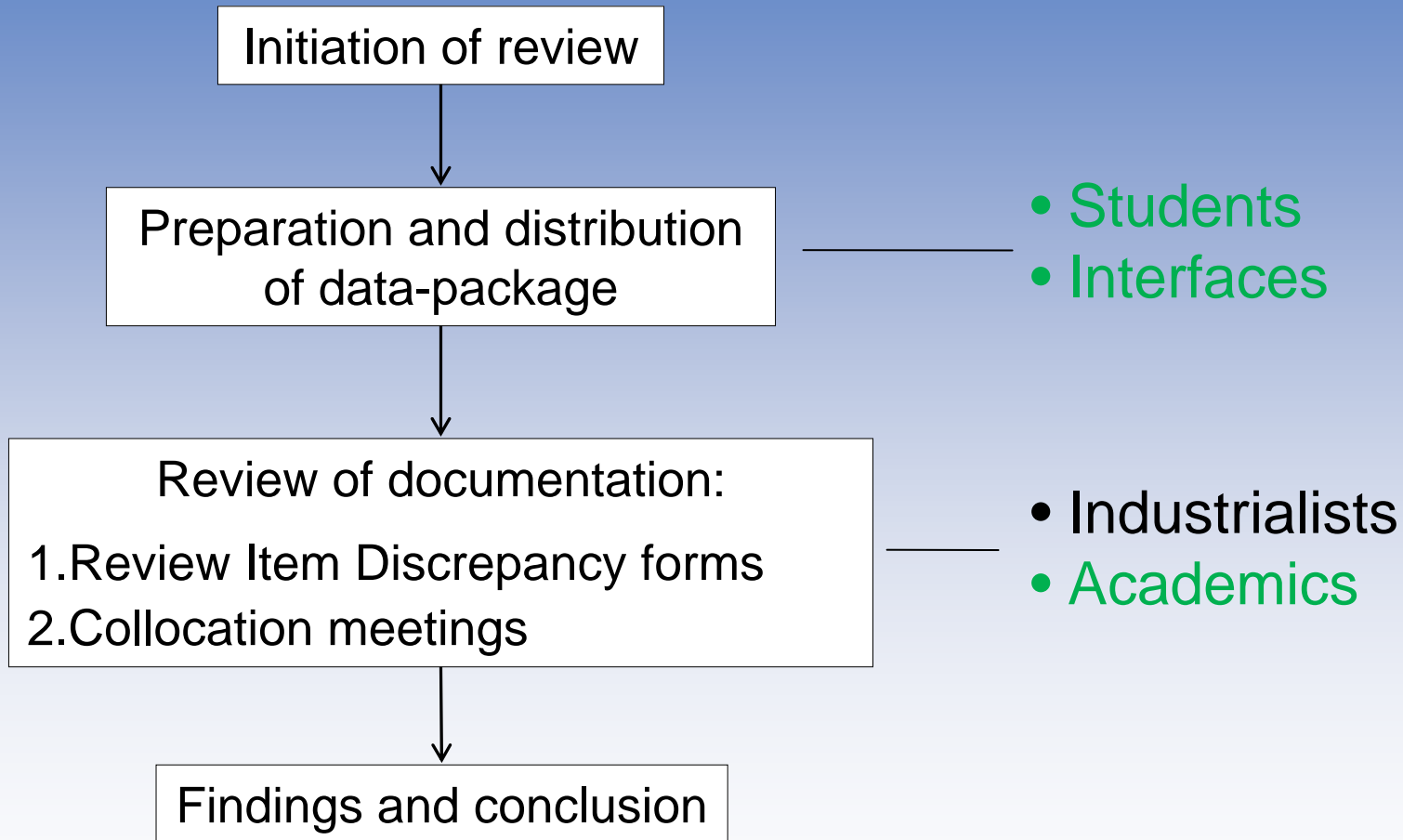

Entities:

<b>ECSS</b>	<b>OUFTI-1 project</b>
Customer	Project manager
Supplier	Students in charge of subsystems
Consumer	(Entity not used)
Review authority	Professor in charge of project
Review team	System engineering team
Review team leader	Member of system engineering team

+ panels



# 3. Practical implementation

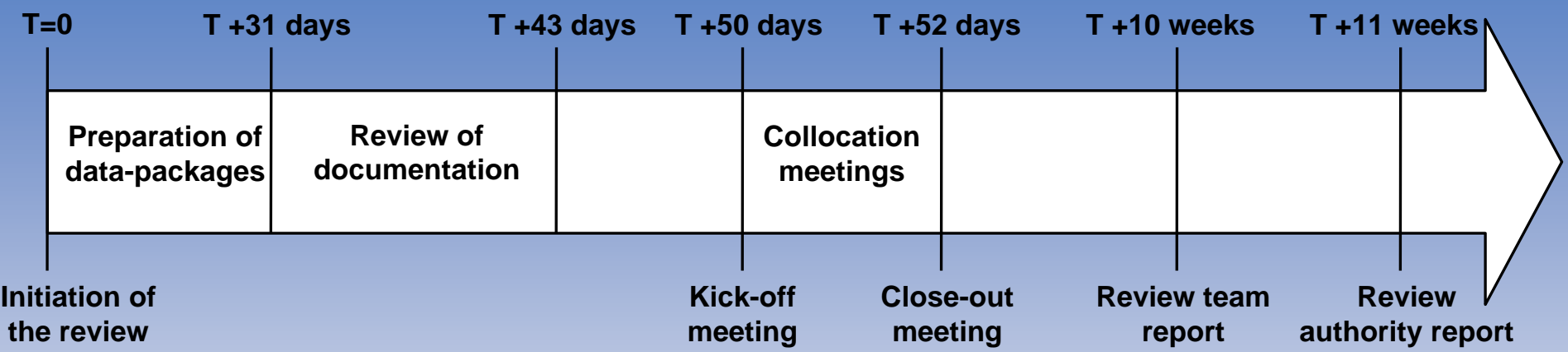

# 4. Evaluation

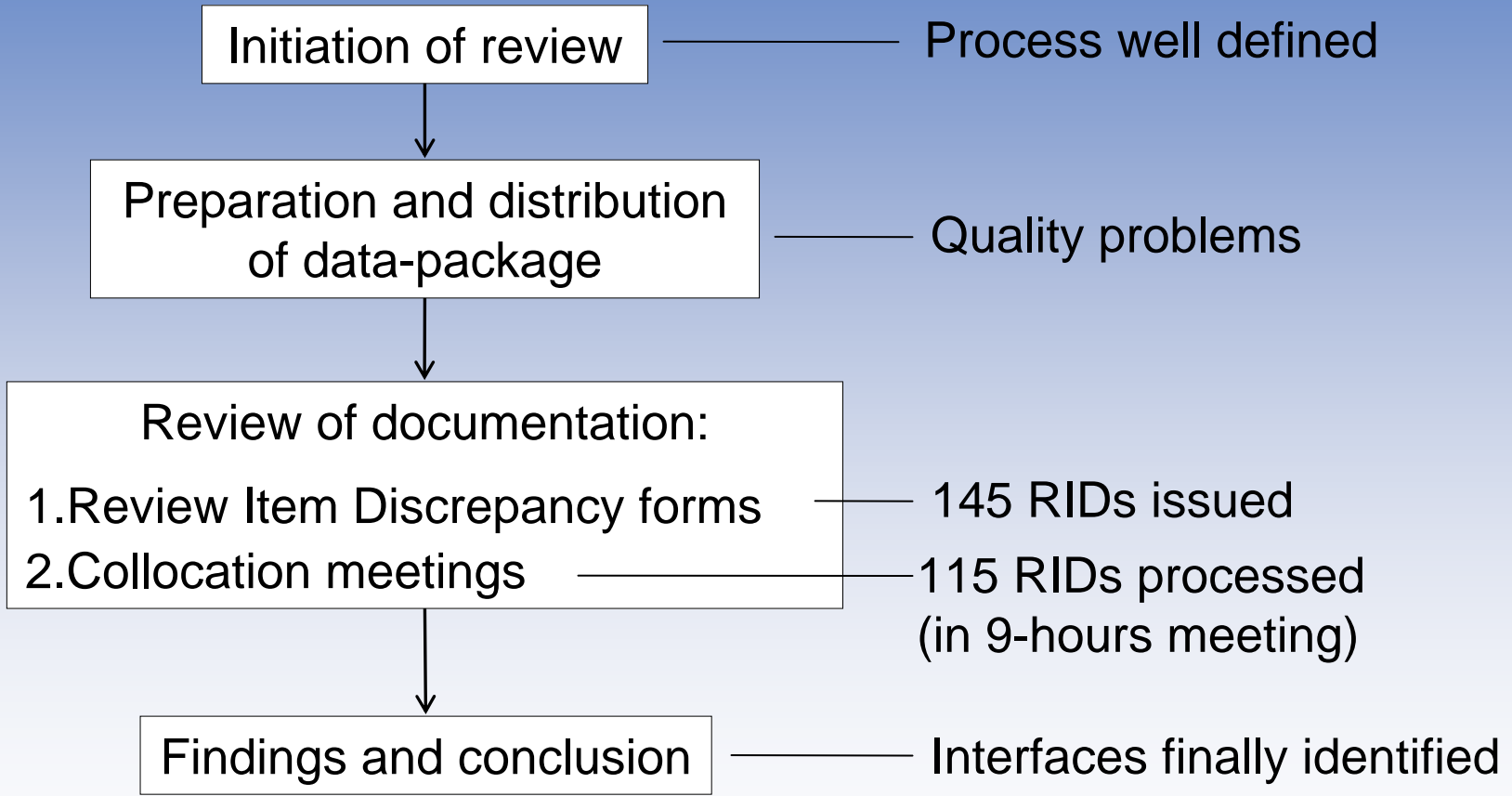

# 5. Conclusion

- ECSS-M-ST-10-01 Standard:
  - Originally designed for industrial application
  - Tailored to academic environment
  
- Review process:
  - Heavy
  - Necessary
  
- Great experience for all

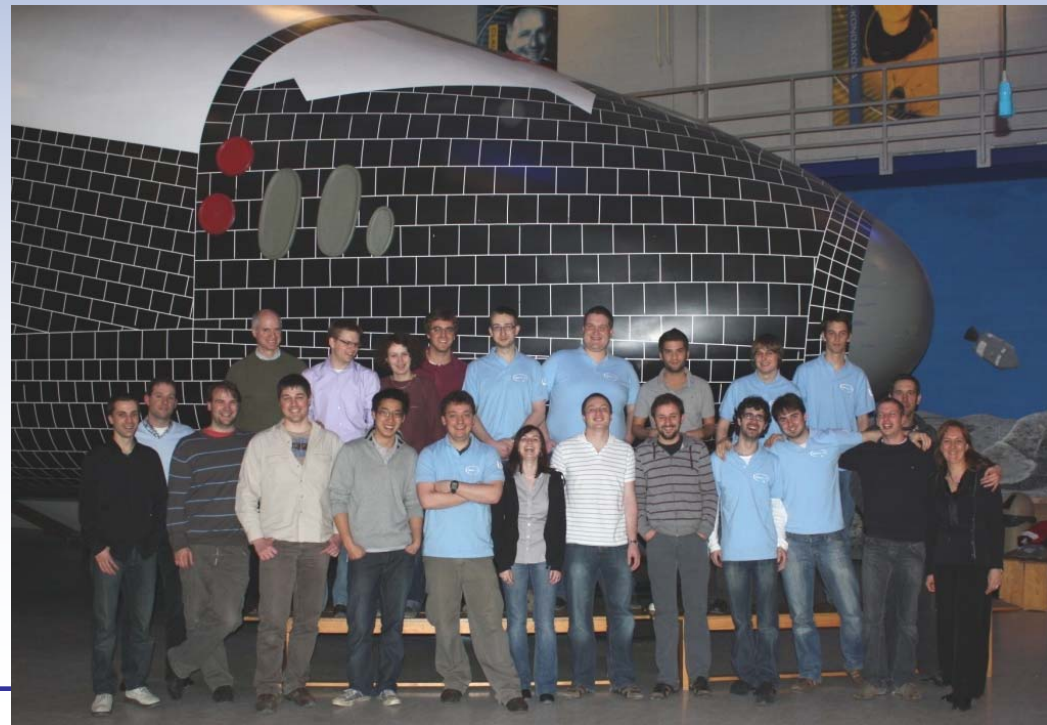



[www.oufti.ulg.ac.be](http://www.oufti.ulg.ac.be)



# Thank you for your attention !

