

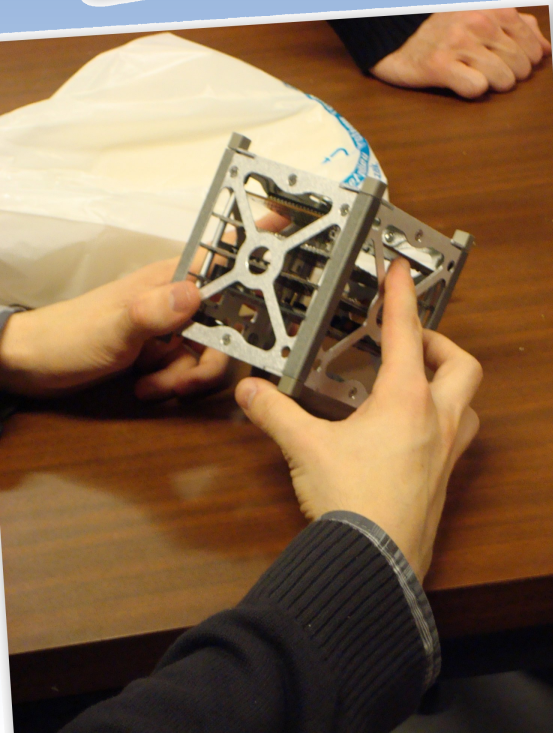

Photo : ESA

Qui, parmi vous, a déjà pensé à devenir astronaute ?



Et qui a déjà pensé à concevoir et lancer son propre satellite ?



Qui pense que des étudiants liégeois peuvent relever le défi ?

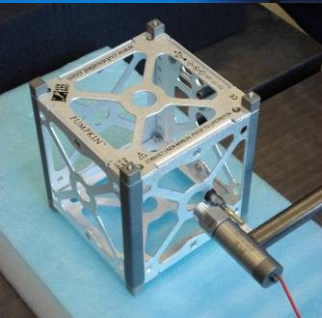
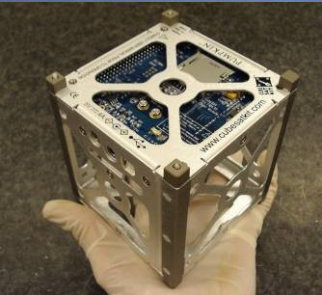

# OUFTE - 1

L'Espace à la portée des étudiants liégeois !



- Le projet en quelques mots
- Aperçu technique
- Une équipe multidisciplinaire
- Quelques concrétisations
- A l'ULg : deux masters
- Conclusions

# 1 Le projet en quelques mots

Objectif n°1 : fun & éducation !

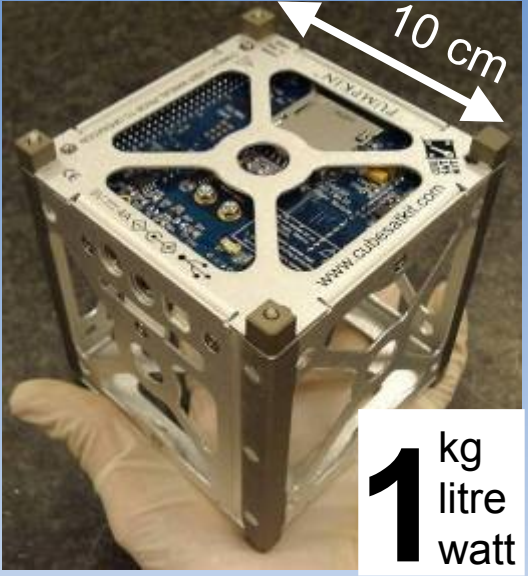

Standard CubeSat

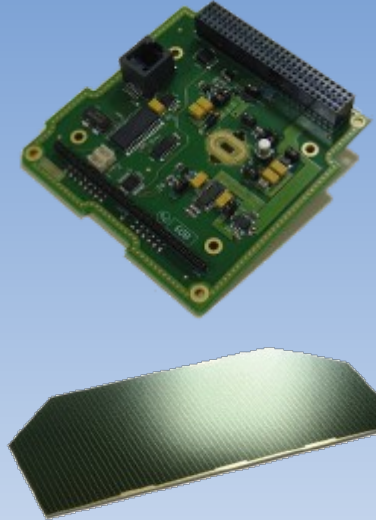

3 expériences



VEGA : octobre 2010

➔ Expérience unique et apprentissages “ inédits ” !

# 2 Aperçu technique

**MECH : maintien & déploiement des antennes**

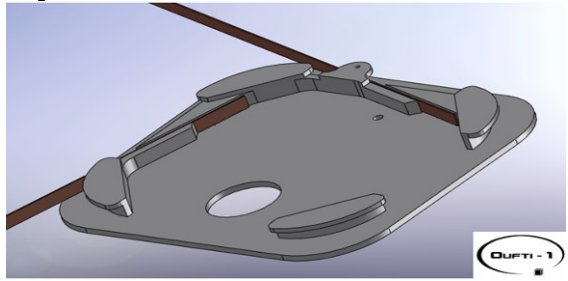

**ADCS : entièrement passif**

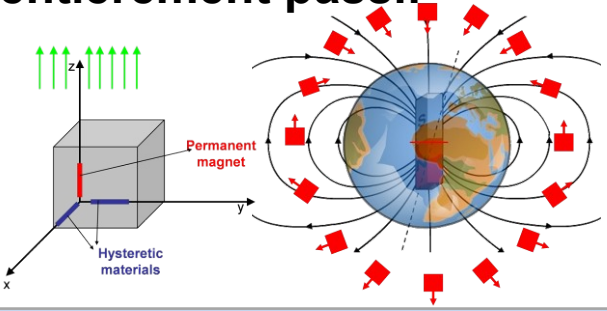

**EPS : classique + expérimental**

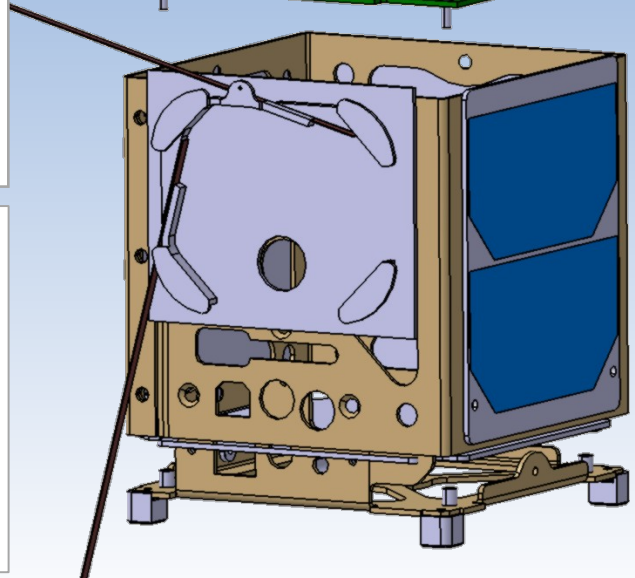
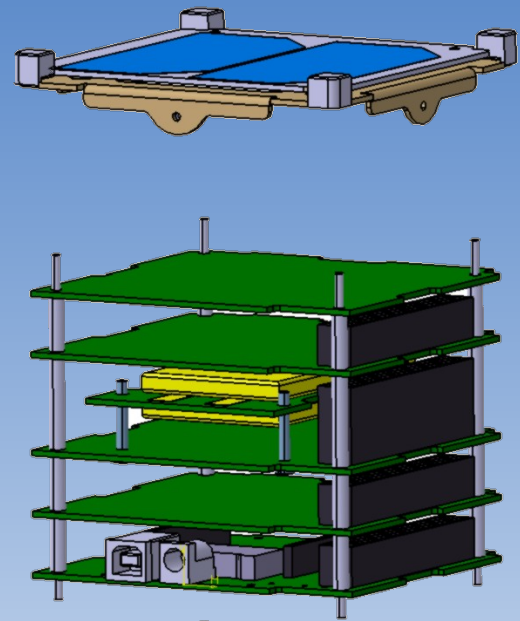
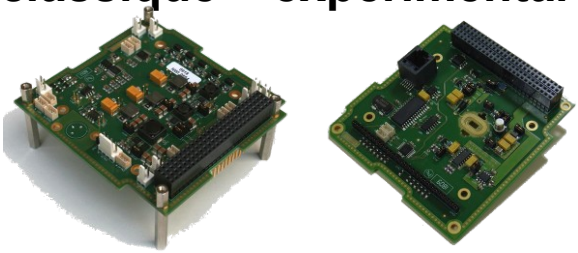

**THER : passif**

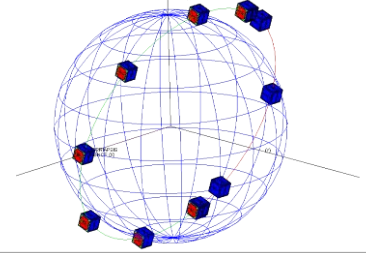

**COM : D-STAR + AX.25 + balise**

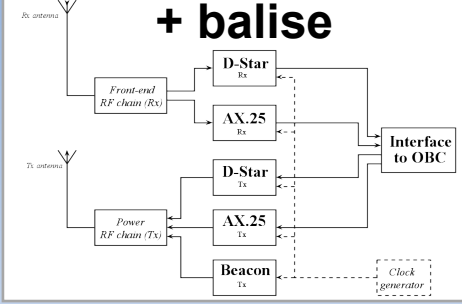

**OBC : kit + « fait-maison »**

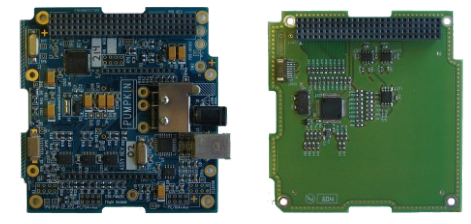

# 3 Une équipe multidisciplinaire



2008-2009 :

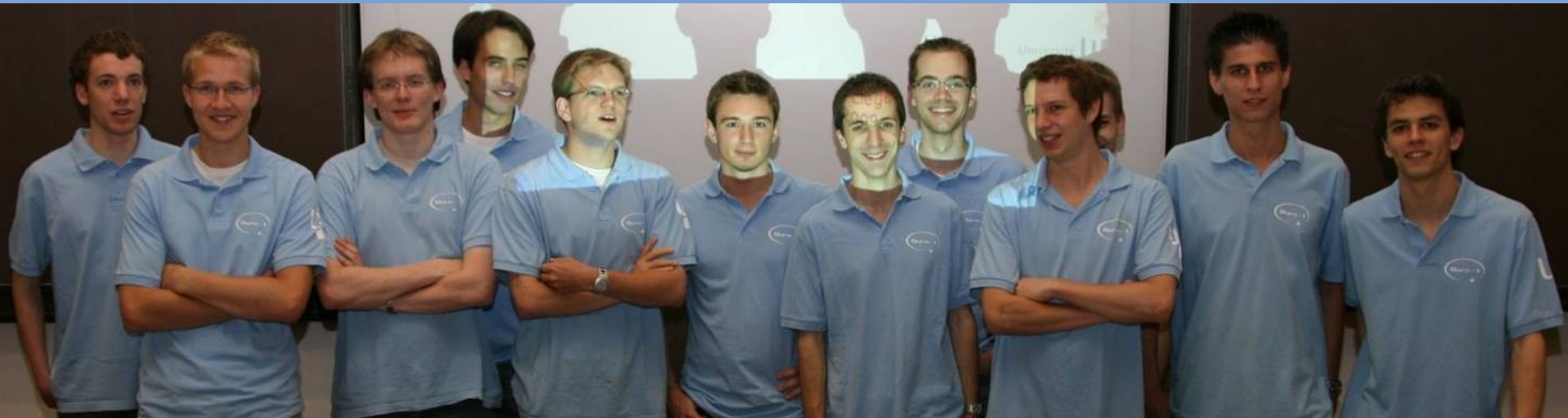

- François  
ULg – Elec.
- Damien  
ULg – Info.
- Gauthier  
ULg – Aéro.
- Nicolas  
Gramme
- Jonathan  
ULg – Elec.
- Pierre  
ULg – Elec.
- Lionel  
ULg – Aéro.
- Renaud  
ISIL
- Jérôme  
Gramme
- Samuel  
ULg – Aéro.
- Johan  
Gramme
- Vincent  
ULg – Aéro.

2009-2010 : 8 ULg, 1 ISIL, 2 Gramme, 1 UCL.

# 4 Quelques concrétisations

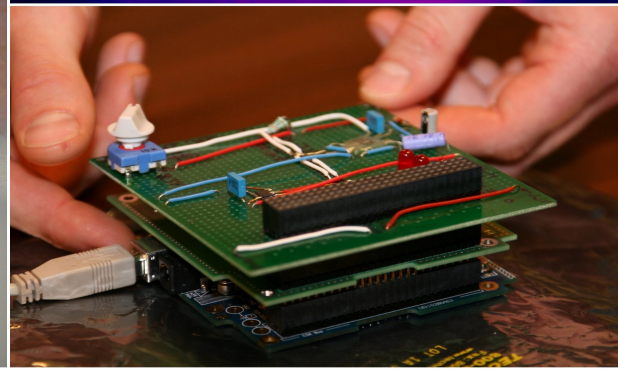
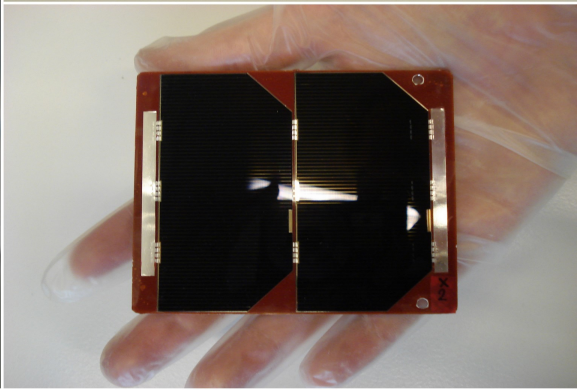
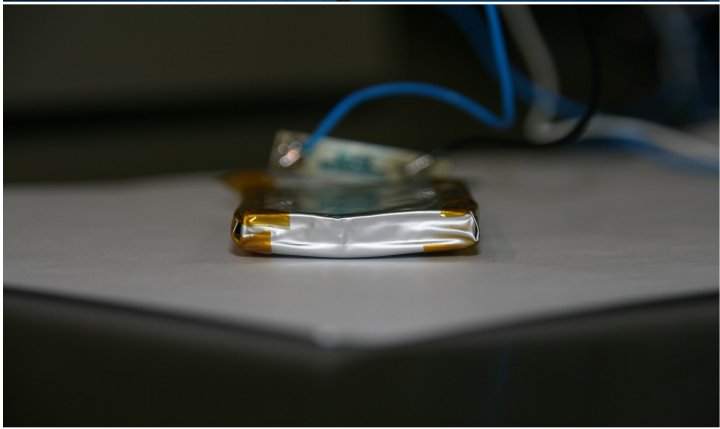
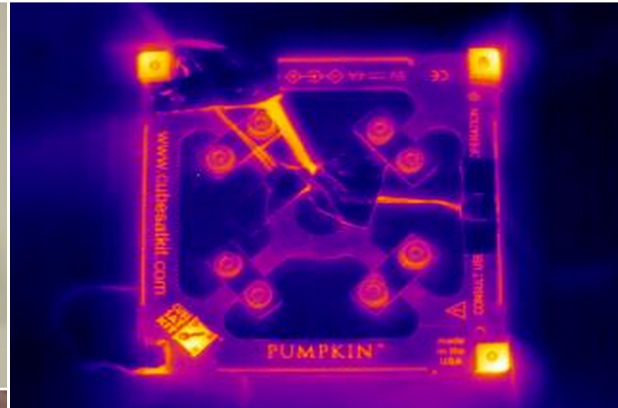
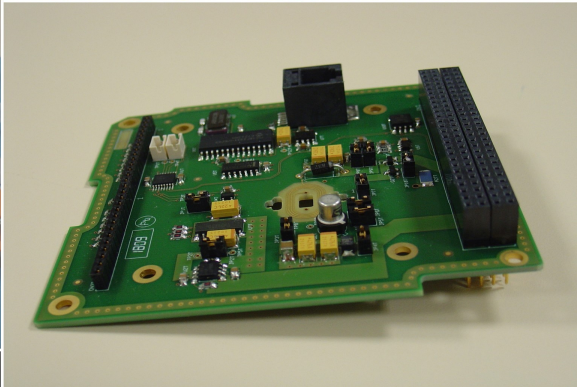
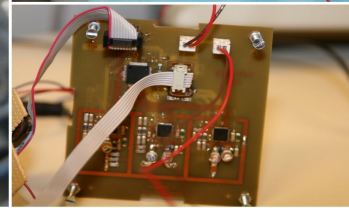
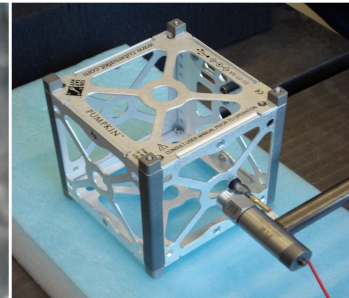
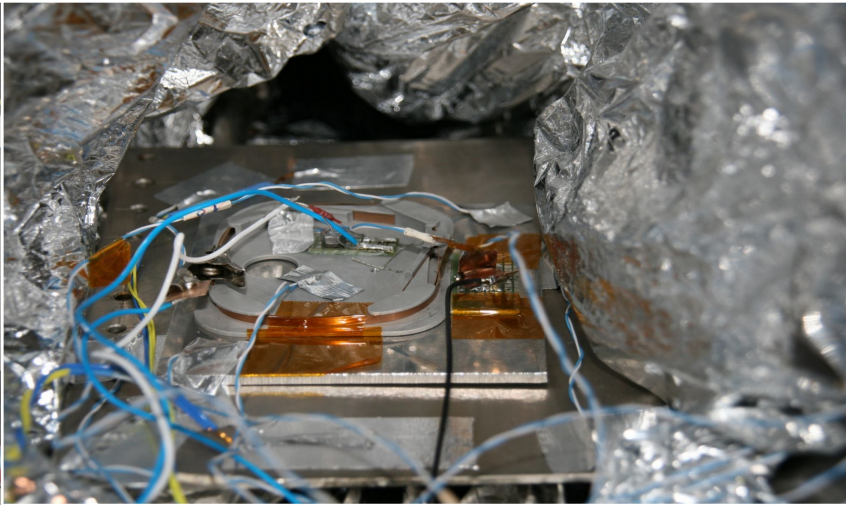
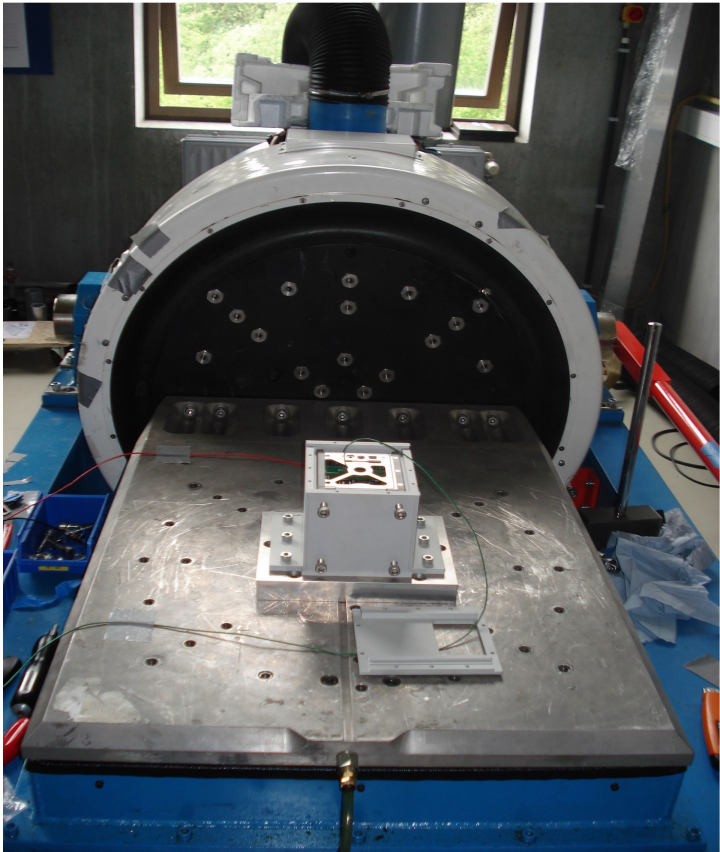



# 5A l'ULg : deux masters

## Master en Sciences Spatiales

Faculté des Sciences

Deux options :

- astrophysique
- sciences de la Terre et des planètes

Accessible aux bacheliers en sciences physiques et en sciences de l'ingénieur

## Master Ingénieur Civil en Aérospatiale

Faculté des Sciences Appliquées

Deux options :

- techniques aéronautiques
- techniques spatiales

Accessible aux bacheliers en sciences de l'ingénieur et en sciences physiques (\*)

Uniques en Communauté Française !



Photo : ESA

# 6 Conclusions

Projet enrichissant, motivant,  
exceptionnel !

Domaine spatial :  
plusieurs formations, profils  
complémentaires.

L'Espace à la portée des  
étudiants liégeois !

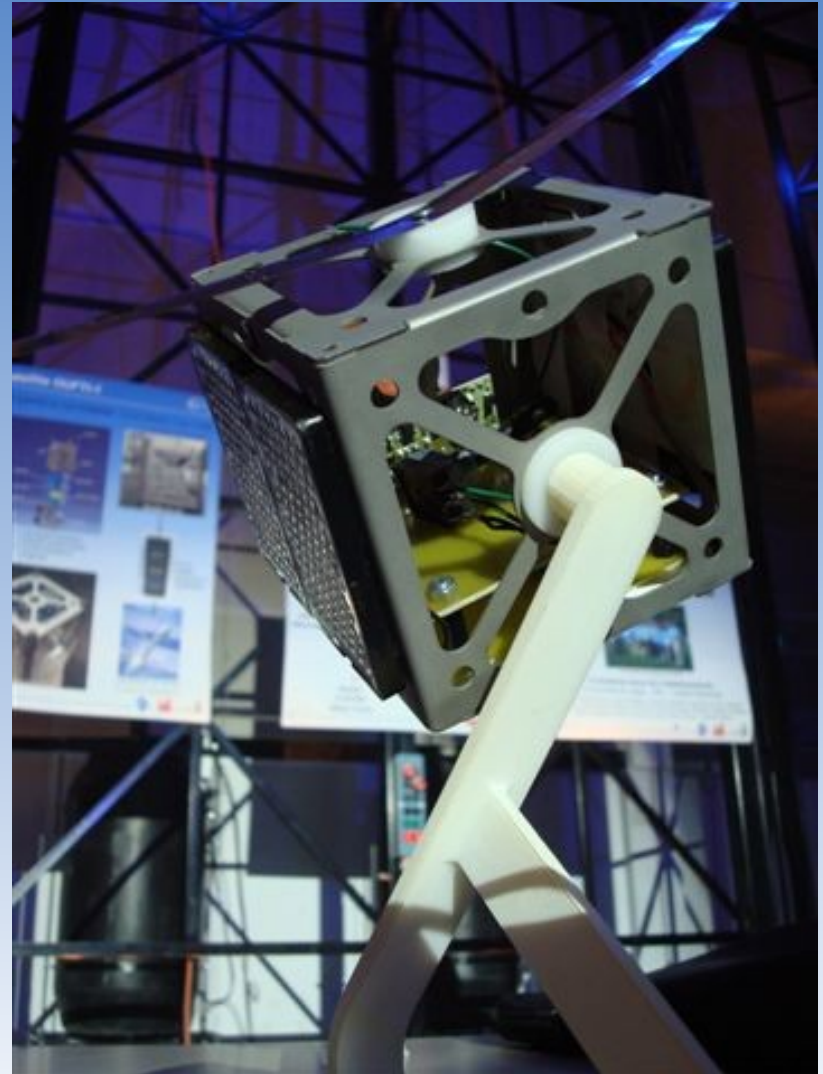

**À suivre...**



[www.oufti.ulg.ac.be](http://www.oufti.ulg.ac.be)



# Merci pour votre attention !

